

# Oscilloscope Fundamentals Primer

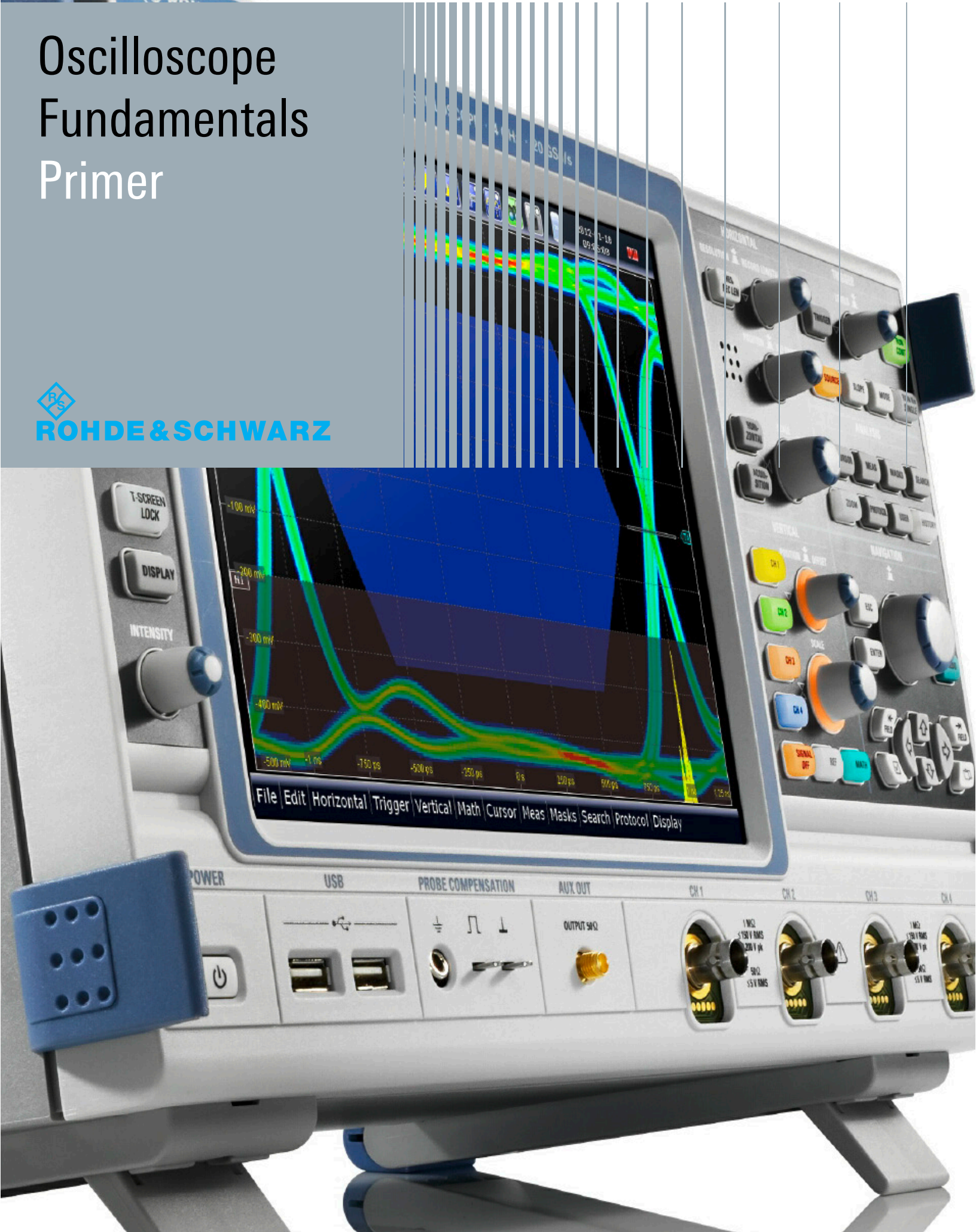

Oscilloscope Fundamentals

Version 1.1

Published by Rohde & Schwarz USA, Inc.

8661 A Robert Fulton Dr., Columbia, MD 21046

R&S® is a registered trademark of Rohde & Schwarz  
GmbH&Co. KG. Trade names are trademarks of the owners.

# Contents

Overview . . . . .	04	Oscilloscope Benchmark Specifications . . . . .	18
Where It All Began . . . . .	04	Bandwidth . . . . .	18
The Digital Age Beckons . . . . .	04	Effective Number of Bits (ENOB) . . . . .	18
Types of Digital Oscilloscopes . . . . .	05	Channels . . . . .	19
Digital Sampling Oscilloscope . . . . .	05	Sample Rate . . . . .	19
Real-Time Sampling Oscilloscopes . . . . .	05	Memory Depth . . . . .	19
Mixed-Signal Oscilloscopes . . . . .	06	Types of Triggering . . . . .	19
Basic Elements of Digital Oscilloscopes . . . . .	06	Rise Time . . . . .	20
The Vertical System . . . . .	06	Frequency Response . . . . .	20
The Horizontal System . . . . .	07	Gain (Vertical) and Time Base (Horizontal) Accuracy . . . . .	21
The Trigger System . . . . .	07	ADC Vertical Resolution . . . . .	21
The Analog Trigger . . . . .	08	Vertical Sensitivity . . . . .	21
The Digital Trigger . . . . .	09	Display and User Interface . . . . .	21
The Triggering Process . . . . .	10	Communication Capabilities . . . . .	21
Trigger Modes . . . . .	11		
Trigger Coupling and Hold-off . . . . .	11	Typical Oscilloscope Measurements . . . . .	22
The Display System and User Interface . . . . .	12	Voltage Measurements . . . . .	22
		Phase Shift Measurements . . . . .	22
Probes . . . . .	13	Time Measurements . . . . .	22
Passive Probes . . . . .	14	Pulse Width and Rise Time Measurements . . . . .	22
Active Probes . . . . .	14	Decoding of Serial Buses . . . . .	22
Differential Probes . . . . .	15	Frequency Analysis, Statistics and Math Functions . . . . .	22
Current Probes . . . . .	15		
High-Voltage Probes . . . . .	15	Summary . . . . .	23
Probe Considerations . . . . .	15	Glossary . . . . .	24
Circuit Loading . . . . .	15		
Grounding . . . . .	16		
Probe Selection Process . . . . .	17		



Figure 1: Nobel Prize-winning physicist K. F. Braun

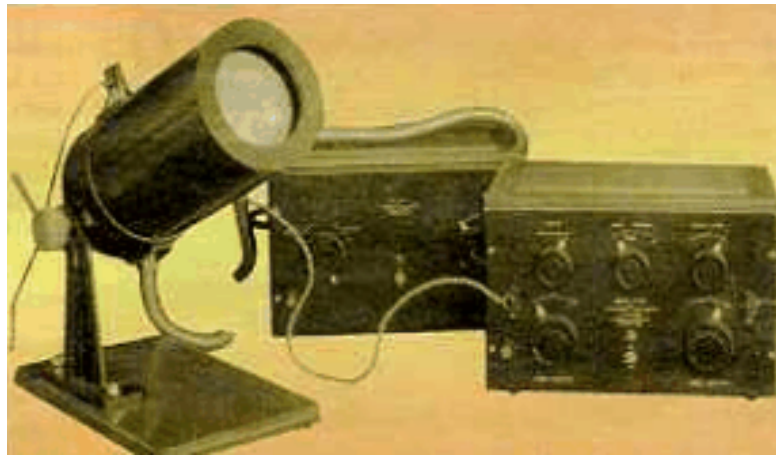

Figure 2: The early oscilloscope

## Overview

The oscilloscope is arguably one of the most useful tools ever created for use by electronic engineers. In the more than five decades since the modern analog oscilloscope was created, hundreds of useful documents and thousands of articles have been written about what it is, how it works, how to use it, and application-specific examples of the “oscilloscope” in action. It is the purpose of this primer to instead describe digital oscilloscopes, which have for practical purposes replaced their analog predecessors in the vast majority of applications. Covered here is a short description of the oscilloscope’s origins, its transition from analog to digital, types of digital oscilloscopes and their major subsystems, key benchmark specifications, and measurements.

### Where It All Began

Nobel Prize-winning physicist K. F. Braun (Figure 1) of Germany invented the CRT oscilloscope as a physics curiosity in 1897. He applied an oscillating signal to horizontal deflector plates and a test signal to a vertical deflector in a phosphor-coated CRT. The plates produced transient plots of electrical waveforms on the small phosphor screen. This invention evolved (Figure 2) into a measurement instrument and was gradually improved over the next 50 years. The advancement by engineer Howard Vollum in 1947 that made the oscilloscope a highly-useful instrument, allowed a trigger to control the sweep function for the first time.

Without a trigger, early oscilloscopes traced the input voltage’s waveform, starting a horizontal trace when the

input voltage exceeded an adjustable threshold. Triggering allowed a repeating waveform to remain stable on the CRT as multiple repetitions of the waveform were drawn over the same trace. If there is no triggering, an oscilloscope will draw multiple copies of the waveform in different places, resulting in an incoherent jumble or a moving image on the screen. Oscilloscopes continued to advance in both capabilities and features over the years in direct relation to the rapid development of high-performance analog and digital semiconductor devices and software.

### The Digital Age Beckons

Digital oscilloscopes began their rise to ubiquity beginning in the 1980s and benefited from faster analog-to-digital conversion and memory for recording and displaying a

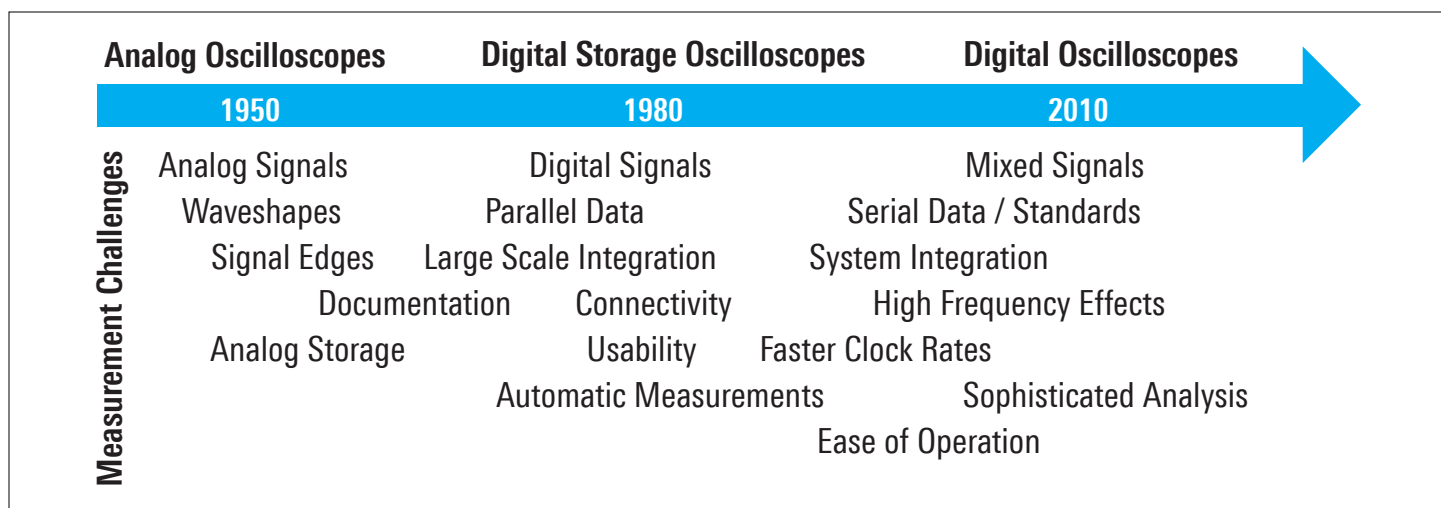

Figure 3: Oscilloscope Measurement Challenges

waveform (Figure 3). Even the earliest digital oscilloscopes provided the flexibility required for triggering, analysis, and display that no analog oscilloscope could provide. Semiconductor and software advancements transformed the instrument's construction from mostly analog to mostly digital. The advantages of processing signals in the digital domain are the same as for all other consumer, commercial, and industrial products, but oscilloscopes in particular gained major advantages. In general, they could now not only manipulate signals in ways never before possible but analyze them in immense detail, while accommodating the special requirements of increasingly complex, high-speed data streams, to name just a very few. They could now let the user capture an event based on specific parameters and see what happened before it occurred as well. Oscilloscopes could now also be part of an automated test system that thanks to local area networks and the Internet allowed them to be operated and their results displayed by users in the next room, next town, or another continent. One of the key benchmarks in digital oscilloscope architecture was the introduction in 2009 of the digital trigger by Rohde & Schwarz, which eliminated the inherent limitations (such as trigger jitter) of analog types. It will be covered in detail later in this document.

## Types of Digital Oscilloscopes

The digital oscilloscope performs two basic functions: acquisition and analysis. During acquisition the sampled signals are saved to memory and during analysis the acquired waveforms are analyzed and output to the

display. There are a variety of digital oscilloscopes and those described here are the most common today.

### Digital Sampling Oscilloscopes

The digital sampling oscilloscope samples the signal before any signal conditioning such as attenuation or amplification is performed. Its design allows the instrument to have very broad bandwidth, although with somewhat limited dynamic range of about 1 V peak-to-peak. Unlike some other types of digital oscilloscopes, a digital sampling oscilloscope can capture signals that have frequency components much higher than the instrument's sample rate. This makes it possible to measure much faster repetitive signals than with any other type of oscilloscope. As a result, digital sampling oscilloscopes are used in very-high-bandwidth applications such as fiber optics, in which their high cost can be justified.

### Real-Time Sampling Oscilloscopes

The benefits of real-time sampling become apparent when the frequency range of a signal is less than half that of an oscilloscope's maximum sample rate. This technique allows the instrument to acquire a very large number of points in a single sweep to produce a highly precise display. It is currently the only method capable of capturing the fastest single-shot transient signals. The R&S®RTO Series oscilloscopes fall into this category.

Board-level embedded systems typically encompass 1-bit signals, clocked and unclocked parallel and serial buses, and standardized or proprietary transmission formats. All

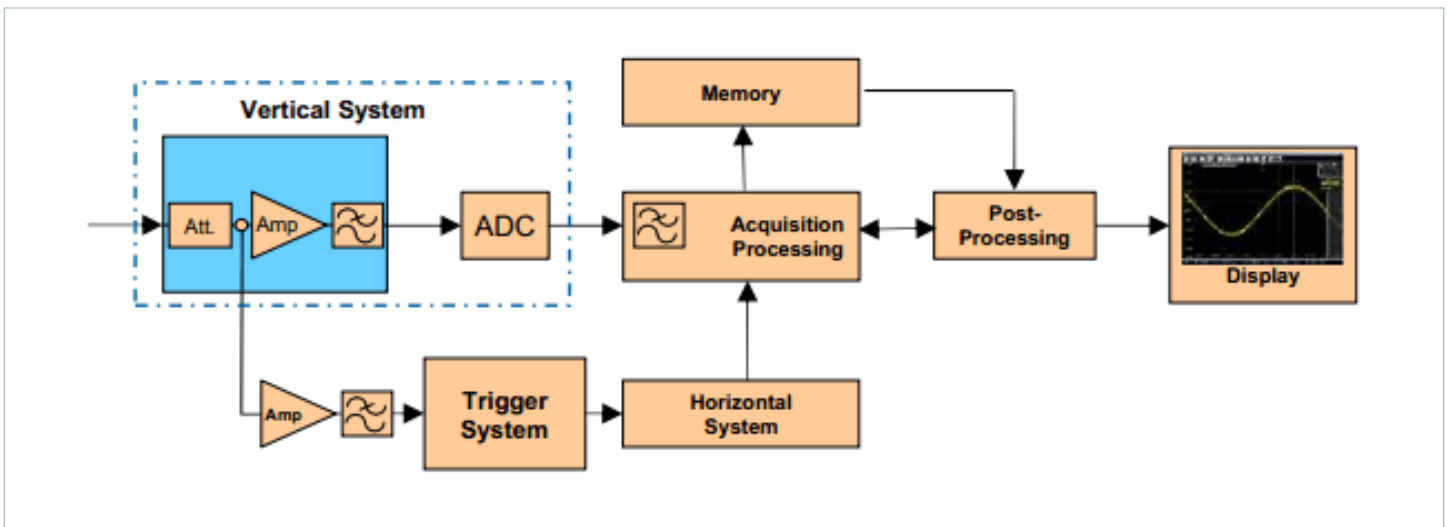

Figure 4: The vertical system

of these paths must be analyzed, which typically requires complex test setups and multiple instruments. It is also often necessary to display both analog and digital signals. For this purpose many oscilloscopes today have specific options, which turn the digital oscilloscope into a hybrid instrument with analysis capabilities of a logic analyzer. This is valuable for quickly debugging digital circuits because of its digital triggering capability, high resolution, acquisition capability, and analysis tools.

### Mixed-Signal Oscilloscopes

Mixed-signal oscilloscopes expand the digital oscilloscope's functionality to include logic and protocol analysis, which simplifies the test bench and allows synchronous visualization of analog waveforms, digital signals, and protocol details within a single instrument. Hardware developers use mixed-signal oscilloscopes to analyze signal integrity, while software developers use them to analyze signal content. A typical mixed-signal oscilloscope has two or four analog channels and many more digital channels. Analog and digital channels are acquired synchronously so they can be correlated in time and analyzed in one instrument.

### Basic Elements of Digital Oscilloscopes

Every digital oscilloscope has four basic functional blocks – the vertical system, horizontal system, trigger system, and display system. In order to appreciate the overall functionality of a digital oscilloscope, it is important to understand the functions and importance of each one.

Much of the front panel of a digital oscilloscope is dedicated to vertical, horizontal, and trigger functions as they encompass the majority of the required adjustments. The vertical section addresses the attenuation or amplification of the signal using a control varying “volts per division”, which changes the attenuation or amplification to fit the signal to the display. The horizontal controls are related to the instrument's time base and its “seconds per division” control determines the amount of time per division shown horizontally across the display. The triggering system performs the basic function of stabilizing the signal, initiates the oscilloscope to make an acquisition, and allows the user to select and modify the actions of specific types of triggers. Finally, the display system includes the display itself and its drivers as well as the software required to implement the many display functions.

### The Vertical System

This oscilloscope subsystem (Figure 4) allows the user to position and scale the waveform vertically, select a value for input coupling, as well as modify signal characteristics to make them appear a certain way on the display. The user can vertically place the waveform at a precise position on the display and increase or decrease its size. All oscilloscope displays have a grid that divides the viewable area into 8 or 10 vertical divisions, each of which represents a portion of the total voltage. That is, an oscilloscope whose display grid has 10 divisions has a total displayable signal voltage of 50 V in 5-V divisions.

Selection of 8, 10, or some other division is arbitrary, and 10 is often chosen for simplicity: It's easier to divide by 10 than by 8. Probes also affect display scaling, as they either do not attenuate signals (a 1X probe) or attenuate them by 10 times (a 10X probe) up to even 1000X. Probes will be discussed later in this document.

The input coupling mentioned earlier basically defines how the signal spans the path between its capture by the probe through the cable and into the instrument. DC coupling provides either 1 Mohm or 50 ohms of input coupling. A 50-ohm selection sends the input signal directly to the oscilloscope vertical gain amplifier, so the broadest bandwidth can be achieved. Selection of AC or DC coupling modes (and corresponding 1-Mohm termination value) places an amplifier in front of the vertical gain amplifier, usually limiting bandwidth to 500 MHz under all conditions. The benefit of such high impedance is inherent protection from high voltages. By selecting "ground" on the front panel, the vertical system is disconnected, so the 0-V point is shown on the display.

Other circuits related to the vertical system include a bandwidth limiter that while decreasing noise in displayed waveforms also attenuates high-frequency signal content. Many oscilloscopes also use a DSP arbitrary equalization filter to extend the bandwidth of the instrument beyond the raw response of its front end by shaping the phase and magnitude response of the oscilloscope channel. However, these circuits require the sampling rate to satisfy Nyquist criteria — sampling rate must exceed twice the maximum fundamental frequency of the signal. To achieve this, the instrument is usually locked into its maximum sampling rate and cannot be lowered to view longer time duration without disabling the filter.

## The Horizontal System

The horizontal system is more directly related to signal acquisition than is the vertical system, and stresses performance metrics such as sample rate and memory depth, as well as others that are directly related to the acquisition and conversion of the signal. The time between sample points

is called sample interval and it represents the digital values stored in memory to produce the resulting waveform. The time between waveform points is called waveform interval and as one waveform point may be built from several sample points the two are related and can sometimes have the same value.

The acquisition mode menu on a typical oscilloscope is very limited because with only one waveform per channel, users can choose only one type of decimation or one type of waveform arithmetic. However, some oscilloscopes can show three waveforms per channel in parallel, and decimation type and waveform arithmetic types can be combined for each waveform. Typical modes include:

- **Sample mode:** A waveform point is created with one sample for each waveform interval.
- **High Res mode:** an average of the samples in the waveform interval is displayed for each interval.
- **Peak detect mode:** The minimum and maximum of the sample points within a waveform are displayed for each interval.
- **RMS:** The RMS value of the samples within the waveform interval are displayed. This is proportional to the instantaneous power.

Typical waveform arithmetic modes include:

- **Envelope mode:** Based on the waveforms captured from a minimum of two trigger events, the oscilloscope creates a boundary (envelope) that represents the highest and lowest values of a waveform.
- **Average mode:** The average of each waveform interval sample is formed over a number of acquisitions

## The Trigger System

The trigger is one of the fundamental elements of every digital oscilloscope as it captures signal events for detailed analysis and provides a stable view of repeating waveforms. The accuracy of a trigger system as well as its flexibility determine how well the measurement signal can be displayed and analyzed. As noted earlier, the digital trigger brings significant advantages for the oscilloscope

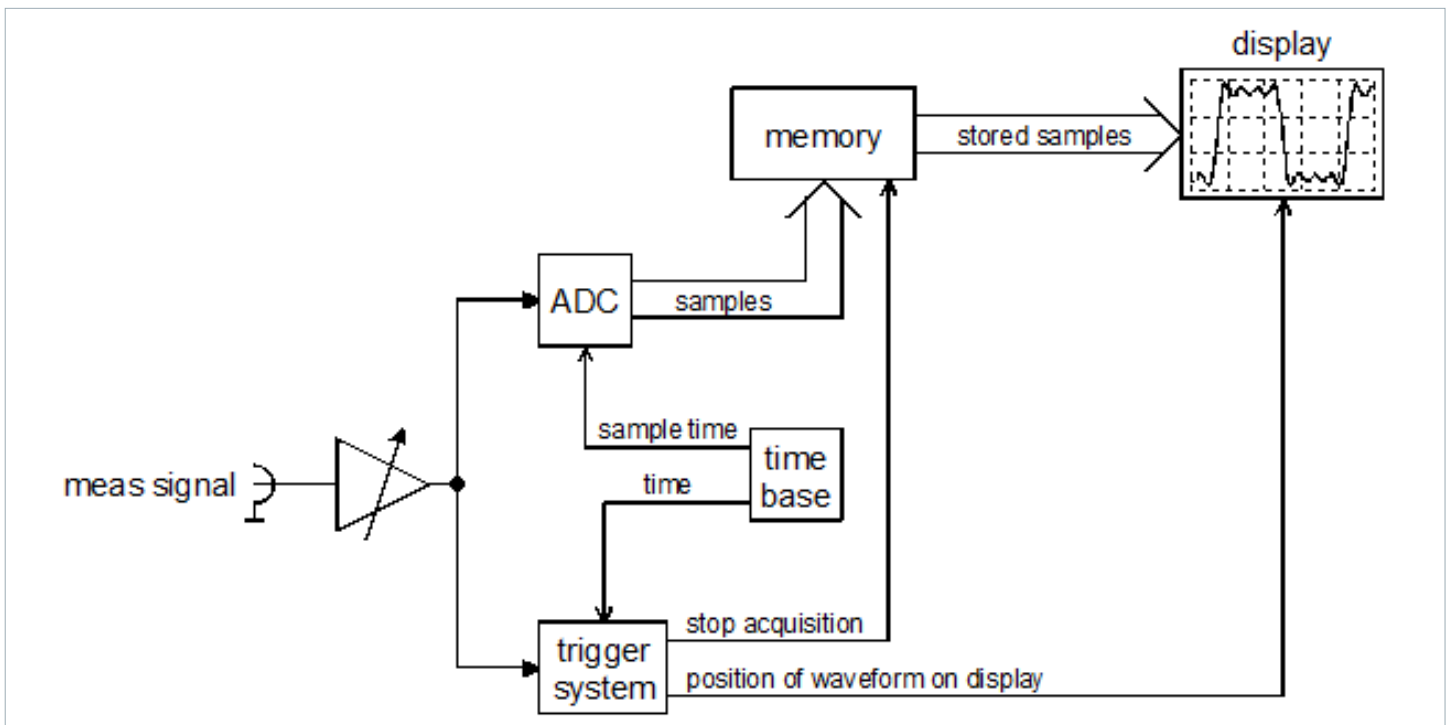

Figure 5: Analog trigger

user in terms of measurement accuracy, acquisition density, and functionality.

### The Analog Trigger

The trigger of an oscilloscope (Figure 5) ensures a stable display of waveforms for continuous monitoring of repetitive signals. As it reacts to specific events it is useful for isolating and displaying specific signal characteristics such as “runt” logic levels that are not reached and signal disturbances caused by crosstalk, slow edges, or invalid timing between channels. The number of trigger events and the flexibility of the trigger have been continuously enhanced over the years.

While a “digital” oscilloscope refers to the fact that the measurement signal is sampled and stored as a continuous series of digital values, the trigger has until recently been exclusively an analog circuit that processes the original measurement signal. The input amplifier conditions the signal under test to match its amplitude to the operation range of the ADC and the display, and the conditioned signal from the amplifier output is distributed in parallel to the analog-to-digital converter (ADC) and the trigger system.

In one path, the ADC samples the measurement signal and the digitized sample values are written to the acquisition memory, and in the other the trigger system compares the signal to valid trigger events such as crossing of a trigger threshold with the “edge” trigger. When a valid trigger condition occurs, the ADC samples are finalized and the acquired waveform is processed and displayed. The crossing of the trigger level by the measurement signal results in a valid trigger event. However, in order to accurately display the signal on the display, trigger point timing must be precise. If it is not, the displayed waveform does not intersect the trigger point (the cross point of trigger level and trigger position).

This can be caused by several factors. First, in the trigger system the signal is compared to a trigger threshold via a comparator and the timing of the edge at the output of the comparator must be measured precisely using a time-to-digital-converter (TDC). If the TDC is inaccurate, an offset of the displayed waveform to the trigger point will occur that causes the offset to change on each trigger event, resulting in trigger jitter.

Another factor is that there are error sources in the two paths of the measurement signal. The signal is processed



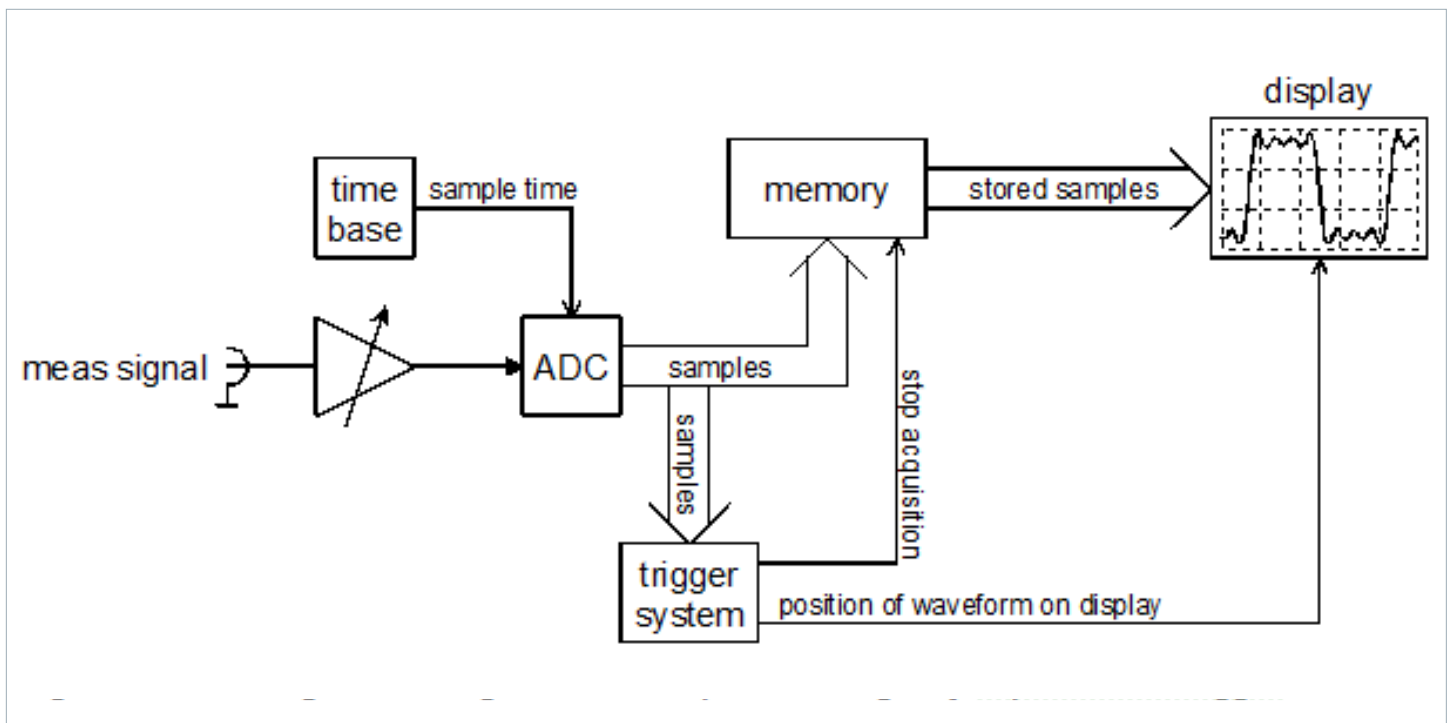

Figure 6: Digital trigger

in two different paths (the acquisition path of the ADC and the trigger path) and both contain different linear and non-linear distortions. This causes a systematic mismatch between the displayed signal and the determined trigger point. In a worst-case scenario, the trigger may not react on valid trigger events even though they are visible at the display or it may react on trigger events that cannot be captured and displayed by the acquisition path.

The last factor is the presence of noise sources in the two paths as they include amplifiers with different noise levels. This causes delays and amplitude variances that appear as trigger position offsets (jitter) on the display. When implemented digitally, the trigger does not include these errors.

### The Digital Trigger

In contrast to an analog trigger, a digital trigger system (Figure 6) operates directly on the samples of the ADC and the signal is not split into two paths but processes the identical signal that is acquired and displayed. As a result, impairments that occur in analog trigger systems are inherently eliminated. To evaluate a trigger point, a digital trigger applies precise DSP algorithms to detect valid trigger events and accurately measures the time stamps.

The challenge is implementing the real-time signal processing required for seamless monitoring of the measurement signal. For example, the digital trigger in the R&S®RTO Series instruments employ an 8-bit ADC sampling at 10 GS/s and processes data at 80 Gb/s. As the digital trigger uses the same digitized data as the acquisition path, triggering on signal events within the ADC range can be achieved. For a selected trigger event, a comparator compares the signal to the defined trigger threshold. In a simple example (an edge trigger), an event is detected when the signal crosses the trigger threshold in the requested direction, either a rising or falling slope. In a digital system the signal is represented by samples and the sampling rate must be at least twice as fast as the maximum frequency of the signal. Only under such conditions can the complete reconstruction of the signal be achieved.

A trigger decision based purely on ADC samples is insufficient because crossings of the trigger threshold can be missed, so the timing resolution is increased by up-sampling the signal using an interpolator to a rate of 20 GS/s. After the interpolator, the comparator compares the sample values to the defined trigger threshold and the output level of the comparator changes if a trigger event is detected.

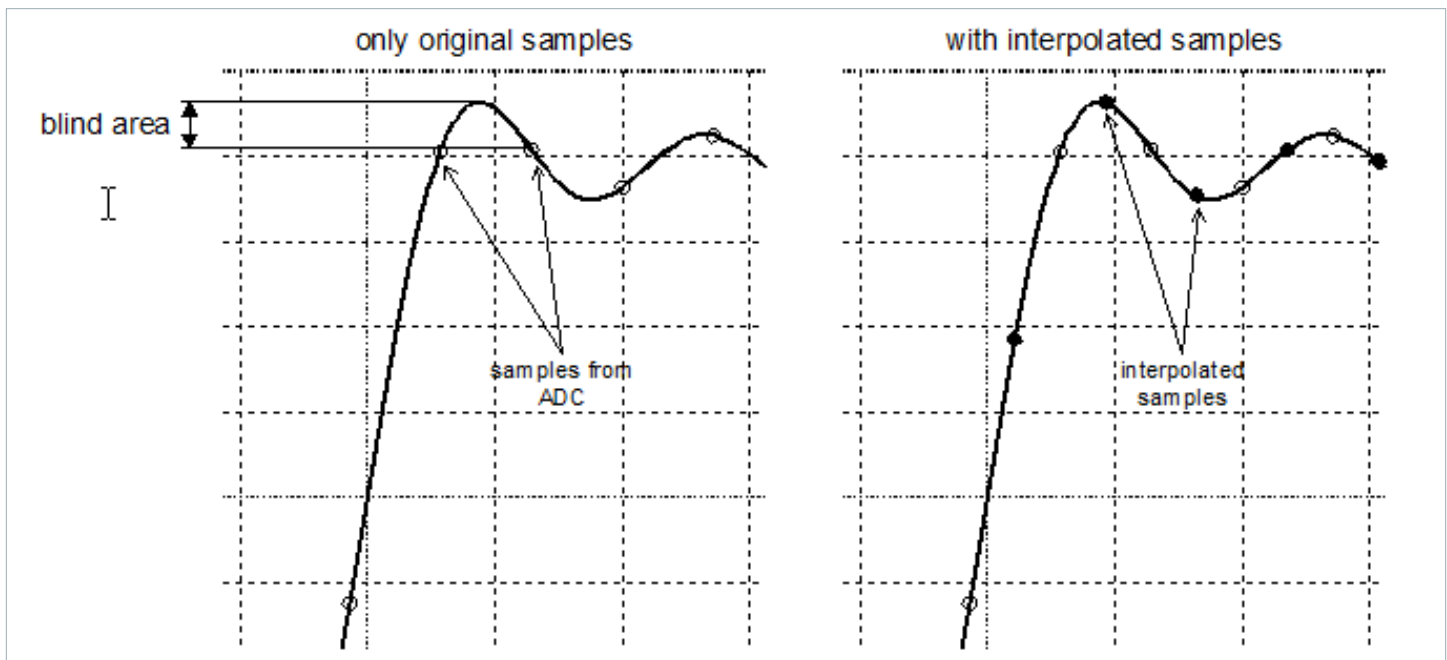

Figure 7: Reduction in “blind” area

Figure 7 shows where the “blind” area in a signal is reduced by enhancing the sample resolution with up-sampling by a factor of two. On the left, the waveform samples do not include the overshoot in the waveform and the trigger threshold above the ADC samples cannot detect the overshoot. On the right, the waveform sampling rate is doubled by interpolation and the triggering on overshoot is possible. The maximum frequency is 3.5 GHz so the digital trigger system can detect frequency components based on the ADC at up to 10 GS/s.

As some trigger events such as glitch and pulse width are based on timing conditions, a digital trigger can very precisely trigger on such events because it determines the intersection points at the threshold in real-time. Timing of trigger events can be set for a resolution of 1 ps, and the minimum detectable pulse width is specified at 100 ps.

Specific benefits of a digital trigger are shown in Table 1.

### The Triggering Process

A triggered sweep starts at a selected point and allows the display of periodic signals such as sine waves or square waves as well as aperiodic signals such as single pulses or pulses that do not recur at a fixed rate. The most common type of triggering is edge triggering, which is set to “enable” when the voltage surpasses some set value. The user can

choose between a rising or falling edge. Glitch triggering allows the instrument to trigger on a pulse that has a width greater than or less than some specified amount of time. This is typically employed when trying to find errors that can occur randomly or intermittently and thus are very difficult to find.

Pulse-width triggering is much like glitch triggering in its mission to seek out specific pulse widths and it allows pulses of any specified width, either negative or positive, to be specified along with horizontal trigger position. The benefit is that the user can see what has occurred before or after the trigger so that if an error is found, viewing what occurred before the trigger was invoked can provide insight into what caused it. If horizontal delay is set to 0, the trigger event will be placed in the middle of the screen and events that occur before the trigger will be seen on the left and those occurring after it on the right.

In addition to these triggers, there are many other types that address specific situations and allow events of interest to be detected. For example, depending on the instrument, the user can trigger on pulses defined by amplitude, time (pulse width, glitch, slew rate, setup-and-hold, and time-out), and by logic state or pattern. Other trigger functions include serial pattern triggering, A+B triggering, and parallel or serial bus triggering.

Low Jitter in Real-Time	As identical sample values are used for both acquisition and trigger processing, very low trigger jitter (below 1 ps RMS) can be achieved. Unlike “software enhanced” trigger systems implemented using post-processing approaches, the digital trigger does not require additional blind time periods after every waveform acquisition. As a result, the R&S@RTO can attain a maximum acquisition and analysis rate of 1 million waveforms per second.
Optimal Trigger Sensitivity	Analog trigger sensitivity is limited to greater than one vertical division and larger hysteresis can be selected with the instrument’s “noise reject” mode for stable triggering on noisy signals. However, a digital trigger allows individual setting of the trigger hysteresis from 0 to 5 divisions to optimize sensitivity for the respective signal characteristic. As a result, precise triggering down to 1 mV/div can be achieved with no bandwidth limitation.
No Masking of Trigger Event	An analog trigger requires time after a trigger decision to rearm the trigger circuit before another trigger can occur. During this time, the oscilloscope cannot respond to new trigger events so they are masked. A digital trigger can evaluate individual trigger events within 400 ps intervals with a resolution of 250 fs.
Flexible Filtering of Trigger Signals	An acquisition and trigger ASIC in the R&S@RTO instruments allows flexible programming of the cut-off frequency of a digital lowpass filter in the real-time path and is usable for the trigger signal, measurement signal, or both. Lowpass filtering on the trigger signal suppresses only high-frequency noise while capturing and displaying the unfiltered measurement signal.
Trigger Recognition of Channel De-skew	The timing relationship between oscilloscope input channels is important for measurement and trigger conditions between two or more signals. Analog triggers provide a signal de-skew feature to compensate for delays on different inputs, which is processed in the acquisition path after the ADC. As a result, it cannot be seen and inconsistent signals are thus displayed and evaluated by the trigger system. A digital trigger uses identical digitized and processed data so the waveforms seen at the display and the signals processed by the trigger unit are consistent even when channel de-skew is applied.

*Table 1: Digital Trigger Benefits*

Digital oscilloscopes can trigger on a single event as well as a delayed trigger event, can control when to look for these events, and reset triggering to begin the trigger sequence again after a specific time, state, or transition. As a result, even events in the most complex signals can be captured.

Digital oscilloscopes have trigger position control, which sets the horizontal position of the trigger in the waveform record. By varying it the user can capture what the signal looked like before the trigger event. It will determine the length of viewable signal before and after the trigger point. The oscilloscope slope control adjusts where the point on the signal the trigger will take place (that is, on either its rising or falling edge).

### Trigger Modes

The trigger mode determines if and under what conditions the oscilloscope will display a waveform. All oscilloscopes have two modes with which triggering can be enabled: a normal mode and an automatic (auto) mode. When set to normal mode, then oscilloscope will trigger only when the signal reaches a specific place on the signal. In its auto mode, the instrument will sweep even if no trigger is set.

### Trigger Coupling and Hold-Off

Some oscilloscopes allow the type of coupling (AC or DC) for the trigger signal to be selected, and in some instruments coupling for high-frequency rejection, low-frequency rejection, and noise rejection as well. The more advanced settings are designed to eliminate noise and other spectral components from the trigger signal in order to prevent false

triggering. Ensuring the oscilloscope triggers on the right part of the signal is sometimes not simple so most instruments provide a way to make it easier with “trigger hold off”, which is an adjustable period of time after a trigger during which the oscilloscope cannot trigger and is useful when triggering on complex waveform shapes to ensure that the oscilloscope triggers only at the desired point.

## The Display System and User Interface

As its name implies, the display system controls all aspects of the signal's presentation to the user. The display's grid markings together form a grid called a graticule or reticle. Digital oscilloscopes and the tasks they perform are complex, so the user interface must be both comprehensive yet comprehensible. For example, the R&S®RTO Series touch-screen display uses color-coded control elements, flat menu structures, and keys for frequently-used functions. In R&S®RTM Series, a single button push invokes a “quick measurement” function that shows values for an active signal. Semi-transparent dialog boxes, movable measurement windows, a configurable toolbar, and preview icons with live waveforms are available as well.



Figure 8: Various types of probes and probe accessories

## Probes

The goal of a probe is to bring the signal from the circuit to the oscilloscope with as much transparency as possible. It is more than simply an oscilloscope “accessory”, as it is the point of contact between the instrument and the device or circuit being measured. Its electrical characteristics, the way it is connected, and its interaction with both the oscilloscope and the circuit have a significant impact on the measurement.

An ideal probe would be easy to connect, have reliable and safe contacts, would not degrade or distort the transferred signal, have linear phase behavior and no attenuation, an infinite bandwidth, high noise immunity, and would not load the signal source. However, in practice all of these attributes are impossible to implement, and in some cases would actually be more than nearly any measurement situation requires. In practice, the signal to be measured is often not easy to reach, its impedance can widely vary, the overall set-up is sensitive to noise and frequency dependent, bandwidth is limited, and differences in signal propagation create slight timing offsets (skew) between multiple measurement channels.

Fortunately, oscilloscope manufacturers go to great lengths to minimize the problems associated with probes and they have been made easier to connect to the circuit and more reliable once in place. For example, operating an oscilloscope with one hand while holding a probe in the other has always been challenging. As an example, the active probes for the R&S®RTO Series oscilloscopes let the

user switch between oscilloscope functions with a button on the probe that can be assigned to various functions. The instrument also has an integrated voltmeter called the R&S®ProbeMeter that allows precise DC measurements to be made that are more accurate than a traditional oscilloscope channel.

The two basic probe types are voltage probes and AC or AC/DC current probes. However, there are many other (Figure 8) types dedicated to specific measurements, including logic probes designed to troubleshoot the logical states of a digital circuit. Environmental probes are designed to operate over broad temperature ranges, and temperature probes measure the temperature of components and places in the circuit in which high temperatures are likely to be encountered. There are also probes designed to be used at the wafer level in probing stations and optical probes that convert optical to electrical signals and make it possible to view optical signals on the oscilloscope, and specific probes for measuring very high voltages.



Figure 9: Active probes

## Passive Probes

The simplest and least expensive of probe types, passive probes provide the bulk of required measurement capabilities. They are essentially composed of wires and connectors and when attenuation is required, resistors and capacitors as well. There are no active components in a passive probe so it can operate without power from the instrument and is inherently rugged.

A 1X (“one times”) probe has the same dynamic range as the oscilloscope, and an attenuating probe extends (multiplies) the range of the instrument by attenuating the signal level by 10X, 100X or more. The most versatile type of probe is the 10X type because it causes less loading and has a higher voltage range. It is the typical “standard” probe supplied with many instruments.

A 1X passive, high-impedance probe connected to the oscilloscope’s 1 Mohm input has high sensitivity (little attenuation), a 10:1 passive, high-impedance probe that also connects to the oscilloscope’s 1 Mohm input provides wide dynamic range, and increased input resistance and low capacitance compared to the 1X probe. A 10:1 passive, low impedance probe that connects to the oscilloscope’s 50 ohm input has little impedance variation over frequency but significantly loads the source because of its nominal impedance of 500 ohms.

A 1X probe is desirable when the amplitude of the signal is low, but when the signal is a mixture of low and moderate amplitude components, a switchable 1X/10X probe is convenient. The bandwidth of passive probes typically

ranges from less than 100 MHz to 500 MHz. In the 50-ohm environments encountered with high-speed (high-frequency) signals, a 50-ohm probe is required and its bandwidth can be several gigahertz and its rise time 100 ps or even faster.

Passive probes include a low-frequency adjustment control that is used when the probe is connected to the oscilloscope. Low-frequency compensation matches the probe capacitance to the oscilloscope’s input capacitance. The high-frequency adjustment control is used only for operating frequencies above about 50 MHz. Vendor-specific passive probes for higher frequencies are adjusted at the factory so only the low-frequency adjustment must be performed. Active probes do not require these types of adjustments because their properties and compensation are determined at the factory.

## Active Probes

The advantages of active probes (Figure 9) include low loading on the signal source, adjustable DC offset of the probe tip that allows high resolution on small AC signals that are superimposed on DC levels, and automatic recognition by the instrument, eliminating the need for manual adjustment. Active probes are available in both single-ended and differential versions. Active probes use active components such as field effect transistors that provide very low input capacitance, which has benefits such as high input impedance that is maintained over a wide frequency range. They also make it possible to measure circuits in which the impedance is not known and allow longer ground leads to be used. As active probes have extremely low loading, they are essential when connected to high-impedance circuits that passive probes would unacceptably load.

However, the integrated buffer amplifier in active probes works over a limited voltage range and the active probe’s impedance is dependent on signal frequency. In addition, even though they can be made to handle thousands of volts, active probes are nevertheless active devices and are not as mechanically rugged as passive probes.

# The Benefits of a Noninterleaved ADC

After the probes, the ADC is the first major oscilloscope component through which the measurement signal passes, and the manner in which it acts on this signal determines how well the processing elements behind it can perform. ADCs for oscilloscopes are generally built up from multiple converters that are interleaved in parallel and together comprise the overall device. However, the alternative – using a single ADC has significant benefits and was chosen by Rohde & Schwarz for the RTO Series.

Even when only a few converter cores are interleaved, it is essential that their noise, phase, and frequency response characteristics vary as little as possible. In addition, interleave timing is critical when measurement intervals are tens of picoseconds and the sampling clock distributed to each converter must also have extraordinarily precise phase characteristics over the device's entire frequency range, which is not a trivial challenge. Timing of each converter within the ADC varies to some degree with respect to the others, so if five converters are interleaved there will be five slightly different sampling clocks, the results of which show up in the frequency domain as components at the fundamental frequency.

These frequency components are typically 40 or 50 dB below full-scale (but nevertheless still clearly visible) and appear periodically so they cannot be averaged out as noise can. They are caused either by timing, mismatched amplitudes, or both. As they exist in both the frequency and time domains they can appear like noise because of the many harmonics at different frequencies that together look like a random signal over time.

This is why some oscilloscope manufacturers use large numbers of converters, as together they produce results that look like noise, which can be identified and mitigated to some degree. However,

*(Continued on page 16)*

## Differential Probes

Although a separate probe for each signal could be used to probe and measure a differential signal, the best method is by using a differential probe. A differential probe uses a built in differential amplifier to subtract the two signals, therefore consuming only one channel of the oscilloscope and also providing substantially higher CMRR (common-mode rejection ratio) performance over a broader range of frequency than single ended measurements. Differential probes can be used for both single-ended and differential applications.

## Current Probes

Current probes work by sensing the strength of an electromagnetic flux field when current flows through a conductor. This field is then converted to a corresponding voltage for measurement and analysis by an oscilloscope. When used in combination with an oscilloscope's measurement and math capabilities current probes allow the user to make a variety of power measurements.

## High-Voltage Probes

The maximum voltage for general-purpose passive probes is typically around 400V. When very high voltages are encountered in a circuit ranging as high as 20 kV, there are probes dedicated to make it possible to safely measure them. Obviously, when making measurements at such high voltages, safety is the primary concern and this type of probe often accommodates it by having a much longer cable length.

## Probe Considerations

### Circuit Loading

The most fundamental and important characteristic that the probe adds to the circuit is loading, of which there are resistive, capacitive, and inductive types. Resistive loading has the effect of attenuating amplitude, shifting DC offset, and changing the circuit's bias. Resistive loading is significant if the probe's input resistance is the same as that of the signal being probed, as some of the current flowing in the circuit enters the probe. This in turn reduces the voltage

(Continued from page 15)

the broadband data signal input into an oscilloscope mixes with the spurious content from these converters, which produces additional spurious content. In short, the oscilloscope's overall noise level (noise plus distortion) limits the number of effective bits that can be derived from an ADC. As interleaving of many converters is a major contributor to noise level, the most obvious way to deal with it is to use one ADC rather than many.

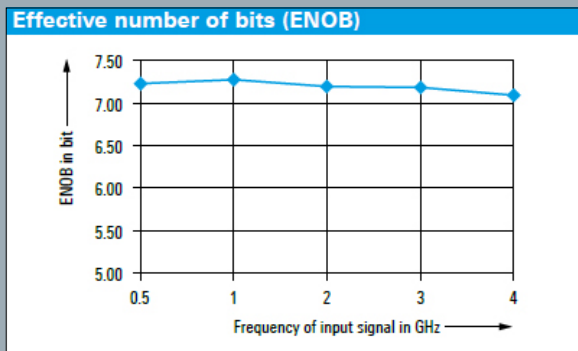

*The consistently high ENOB of the A/D converters in the R&S®RTO oscilloscopes ensures accurate representation of signal details as well as a very high dynamic range.*

This is why Rohde & Schwarz chose this approach in the R&S®RTO Series. The device is a single flash converter with 8 bits of resolution that samples at 10 GS/s, and achieves an ENOB of 7 (out of eight). The result is a decrease in system noise floor by about 6 dB, which improves signal-to-noise ratio and dynamic range so very small voltages can easily be discerned.

In addition, frequency domain measurements such as channel power, total harmonic distortion, and adjacent channel power can be more accurately determined because the spectrum is not cluttered by oscilloscope-generated noise. This performance is exploited by a custom ASIC that dramatically increases the speed at which the instrument can proceed from raw integer ADC samples to a measured waveform. With 40 million sample waveforms, for example, a typical oscilloscope might require several minutes for acquisition to complete while the R&S®RTO performs this operation in fractions of a second.

where the circuit meets the probe. It can actually cause a circuit that is malfunctioning to work properly but more typically to causes it to work improperly. To reduce the effect of resistive loading, it is generally desirable to use a probe with a resistance greater than 10 times the resistance of the circuit under test.

Capacitive loading decreases the speed of rise time, reduces bandwidth, and increases propagation delay, and is caused by the capacitance in the probe tip. It introduces measurement errors that are frequency dependent, and is the greatest problem when making delay and rise time measurements. Capacitive loading is caused by the probe's capacitance acting as a lowpass filter at high frequencies, which shunts the high-frequency information to ground and significantly reduces the probe's input impedance at high frequencies. Probes with tips that have low capacitance are thus highly desirable.

Inductive loading distorts the measurement signal and is produced by the inductance of the loop formed from the probe tip to the probe ground lead. The ringing in the signal caused by inductive loading in the ground lead in conjunction with the capacitance of the probe tip can be mitigated by effective grounding, which increases the frequency of ringing to beyond that of the bandwidth of the instrument. The length of the ground lead should always be as short as possible so as to reduce the size of the loop which minimizes the inductance. Lower inductance will minimize the ringing on top of the measured waveform.

## Grounding

Proper grounding is essential when making oscilloscope measurements to achieve accuracy as well as to ensure the operator's safety, especially when working with high voltages. The instrument must be grounded via a power supply cord and must never be operated with the "Protective Earth" disconnected. This can result in unwanted low-frequency hum if the signal ground of the DUT is connected to ground via the mains at a different location causing a ground loop. Common practice is to have the signal ground insulated from the mains ground



and to create a connection to the signal ground close to the signal pin.

### Probe Selection Process

Two factors are most decisive for choosing the right (voltage) probe: the bandwidth required to capture the waveform without distortion and the desired minimum impedance to minimize circuit loading. The specified oscilloscope bandwidth is valid only for a 50-ohm input impedance and a limited voltage input range. The instrument bandwidth must be at least five times the highest pulse frequency to be measured in order to preserve the harmonics and thus waveform integrity.

Specified DC impedance has little value for AC measurements. Over frequency, the impedance decreases, most dramatically for passive probes. Trying to keep the input impedance at least 10 times as high as the source impedance at the highest signal frequency, the choice between an active or passive probe is simple. This may nevertheless narrow the choice to only one or two probe models that come closest to meeting the requirements for the measurement setup. Active probes are mandatory to draw full benefit of an oscilloscope bandwidth in the microwave region.

Remember that low frequency impedance is highest in a 10x passive probe, and passive probes in general do not carry DC offsets or introduce noise. Active probes offer constant impedance at frequencies of hundreds of kilohertz and highest impedance up to several 100 MHz. Low-impedance probes offer constant impedance up to 1 GHz, and while impedance at one frequency may be desirable a constant but lower impedance avoids distortion of signals with harmonics.

In short, active probes are recommended for signals with frequency components above 100 MHz, and low input capacitance results in a higher resonance frequency. Connections to active probes must be as short as possible to ensure a high usable bandwidth. In addition, if the ground level appears unstable, a differential probe may be required.

With passive probes, it is important to use the model recommended for the particular instrument in use, even if the probe has a higher bandwidth specification than seems necessary. Low input capacitance results in a higher resonance frequency. The ground lead should be short to minimize ground lead inductance. Be careful when measuring steep edge rise times, as the resonance frequency can be much lower than the system bandwidth. The probe's impedance should be about ten times the circuit test point impedance as not to load the circuit too heavily.

# Oscilloscope Benchmark Specifications

As with all electronic test equipment, digital oscilloscopes have an array of key specifications. Some are simple but others are either specified in various ways depending on the manufacturer or can be in some other way confusing. Consequently, the definitions below are largely generic.

## Bandwidth

Maximum bandwidth is the preeminent specification noted by every digital oscilloscope manufacturer, and for good reason: It determines the frequency range the oscilloscope can accurately measure. If the instrument's bandwidth is inadequate for a specific application, the instrument will essentially cease to be an accurate, useful measurement device, as there will not be enough content available for it to display the signal. Oscilloscope bandwidth is defined as the lowest frequency at which the input signal is attenuated by 3 dB, that is, where a sine wave signal would be attenuated to 70.7 % of its true amplitude.

Selecting the proper bandwidth for a given application can be difficult. Obviously, the simplest way to satisfy this requirement is to select an instrument with the highest bandwidth. However, the price of very-high-bandwidth oscilloscopes can be prohibitive. In addition, noise level increases and dynamic range decreases significantly with increased bandwidth. This can increase measurement uncertainty as much as inadequate bandwidth. Consequently, it is best to choose an oscilloscope with the least bandwidth for the applications and signals the user is likely to encounter.

Oscilloscopes are used primarily to measure digital pulses, and an ideal pulse with infinite bandwidth is a square wave. The frequency spectrum of this signal consists of a signal at the fundamental frequency and odd harmonics. The amplitude of the harmonics follow a  $\sin(x)/x$  function in frequency so the third harmonic is about 13.5 dB below the fundamental and the fifth harmonic is 27 dB below it. The next harmonic, the seventh, is 54 dB and below the noise floor of most oscilloscopes. A common rule of thumb for choosing oscilloscope bandwidth is the so-called "fifth harmonic rule" and is based on the square wave spectrum. In many cases, however, this rule leads to an overly high bandwidth choice.

The spectrum described above applies to a perfect square wave but all digital signals have a finite rise time that modifies the ideal square wave spectrum by reducing the amplitude of higher-order harmonics. In many cases, the level of the fifth harmonic is well below the noise floor of the oscilloscope and less bandwidth is adequate. This is typically true for signals with bandwidths of 3 Gb/s and higher such as serial data signals whose rise time relative to bit interval is about 30%. In this case, a bandwidth of less than 5 times the fundamental is acceptable for accurate measurements.

Achievable bandwidth is also directly affected by the probe, which is not an ideal device and thus has its own bandwidth that must be taken into consideration. The probe bandwidth should always be greater than the bandwidth of the oscilloscope, with a figure of 1.5 times greater a good rule of thumb. Thus for a 1-GHz oscilloscope, a probe with a bandwidth of 1.5 GHz is required to ensure that full performance can be realized. Greater probe bandwidth is important to ensure that the test signals are within the probe's flat frequency response region. For a "typical" oscilloscope that has a bandwidth of 1 GHz, this region would typically be one third of the maximum probe bandwidth specification, or 300 MHz.

More specifically, most test signals are more complex than a simple sine wave and include various spectral components such as harmonics. To view digital signals, for example, the oscilloscope should provide about five times greater bandwidth than the clock frequency. For analog signals, the highest frequency of the device to which the oscilloscope is connected determines the required oscilloscope bandwidth.

## Effective of Number of Bits (ENOB)

Effective number of bits (ENOB) is a specification that can be confusing as it can refer to both the bits of resolution achievable by the ADC as well as the total "effective" number of bits that it can achieve when part of a complete

instrument. The first is invariably more than the second and neither specification is ever seen on an oscilloscope data sheet. However, ENOB is a good acronym to know about. ENOB is dictated by a variety of factors, varies with frequency, front-end noise, harmonic distortion, and interleaving distortion, among other factors. Oscilloscope vendors tout the nearness of their instrument's ENOB to the "raw" value (such as over 7 out of 8 bits in the case of the R&S®RTO Series) as it is not a trivial achievement. (See *"The Benefits of a Noninterleaved ADC," p. 15*)

## Channels

Most digital oscilloscopes once had 2 or 4 channels but today they can have 20, the result of the need to measure analog and complex digital signals. For the oscilloscope buyer, it is essential that the number of channels likely to be encountered is correctly estimated, as the alternative is building external triggering hardware. When used in embedded debugging applications, mixed-signal oscilloscope for example will interleave 16 logic timing channels with the instrument's traditional 2 or 4 channels.

## Sample Rate

The sample rate of the oscilloscope is the number of samples it can acquire within 1 s and should be at least 2.5 times greater than oscilloscope bandwidth. As the latest digital oscilloscopes have extremely high sample rates and bandwidths in excess of 6 GHz, they are typically designed to accommodate high-speed, single shot transient events. They achieve this by oversampling at rates that can be greater than five times the stated bandwidth. While oscilloscope manufacturers specify the maximum sample rate of their instruments, it can often be achieved only when one or two channels are being used. If more channels are simultaneously used, the sample rate is likely to decrease. So the key determinant is then how many channels can be used while still achieving the maximum sample rate of the instrument. As with any system in which analog signals are converted to digital ones, the greater the sample rate the greater the resolution and in the case of a digital oscilloscope the better the displayed result will be.

## Memory Depth

This specification is important because as sample rate increases, the amount of memory required to store captured signals increases as well. The greater the instrument's memory the more waveforms it can capture at its full sample rate. Generally speaking, long-term capture periods require significant memory depth but oscilloscopes can suffer a significant drop in update rate when the deepest memory depth setting is selected.

While performing signal acquisition, conventional oscilloscopes continuously save, process, and display data. While all this is happening, the instrument is essentially "blind" to the characteristics of the signal being measured. At the highest sampling rates, blind time can actually be greater than 99.5% of the entire acquisition time so measurements are only being made less than 0.5% of the time, which hides signal faults. Perhaps the most critical need for sufficient signal-capture memory is when an event occurs randomly or very infrequently. With too little memory, the likelihood that the event will not be captured rises dramatically. In addition to high-speed memory, oscilloscopes such as the R&S®RTO Series instruments employ an ASIC that runs multiple processes in parallel, which dramatically reduces blind time and enables analysis speed to approach 1 million waveforms per second, 20 times faster than other instruments.

## Types of Triggering

Fortunately for the prospective oscilloscope buyer, most oscilloscopes come with a variety of traditional triggering capabilities as well as some dedicated to common applications. This is important as there are many types of triggering that can be performed and some applications cannot be adequately addressed without them. Virtually every digital oscilloscope includes edge, glitch, and pattern triggering. Mixed-signal oscilloscopes make it possible to trigger across both logic and oscilloscope channels. Engineers working with common serial interface buses will require triggering protocols for SPI, UART/RS-232, CAN/LIN, USB, I2C, FlexRay, and others, so potential

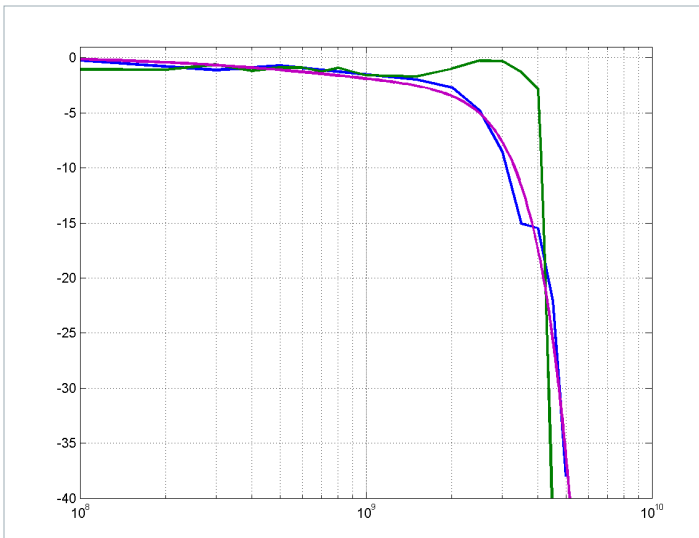

Figure 10: The Gaussian frequency response curve of the R&S@RTO1024 (blue) and that of maximally-flat oscilloscope (green) superimposed on an ideal Gaussian response (violet) show how close the latter comes to an ideal response.

triggering requirements are part of the oscilloscope specification process.

## Rise Time

The vast majority of applications today require measurement of rise time, especially when measuring digital signals that require very fast rise time measurements, so this metric is more important than ever. In fact, an oscilloscope's rise time determines the actual useful frequency range that it can achieve. An oscilloscope with faster rise time can more accurately represent the details of high-speed transitions. When applied to a probe, its response to a step function indicates the fastest period that the probe can transmit to the input of the oscilloscope input. The general rule regarding this specification is that to achieve accurate pulse rise and fall time measurements, the rise time speed of the complete system, that is, the oscilloscope and probe, should be three to five times that of the fastest transition it will encounter.

## Frequency Response

Frequency response is just one of many characteristics that determine the performance of a digital oscilloscope but it is a major contributor to oscilloscope performance — even though it is never stated on an oscilloscope manufacturer's data sheet. It remains in the shadows mostly because a Gaussian frequency response shape was always assumed when oscilloscopes and signal were analog. However, a

digital oscilloscope can have maximally-flat, Chebyshev, Butterworth, Gaussian, or some other frequency response curve, and each type impacts the overshoot and ringing that contribute to errors in amplitude and rise time in different ways, so it is important to understand this “mystery” specification.

For example, all signals are the sum of sine waves at different frequencies and phases appearing in the frequency domain as spectral lines, each one weighted separately by the frequency response of the oscilloscope. Obviously, how the frequency response weights each one of these signals components would be beneficial, but the user can only guess at what it might be, as only 3-dB bandwidth and rise time are specified on the data sheet.

Every manufacturer has its own idea of what an “ideal” frequency response curve would be. Some believe that a maximally-flat response provides the best results, as this response type does not deviate all the way to the instrument's cutoff frequency after which it drops off precipitously. It also allows the instrument's frequency range to be extended, resulting in very sharp roll-off characteristics.

The maximally-flat frequency response requires significant trade-offs to be made in order to achieve it. For example, a penalty is paid at the transition frequency as there is no way the response can be perfectly flat and also transition without a “bump” occurring in the response at higher frequencies. Butterworth, Chebyshev, and other types of responses also produce some irregularity in the passband, even with current state-of-the-art of digital filters.

Rohde & Schwarz believes that the traditional Gaussian response represents the best trade-off between conflicting specifications and provides the best overall accuracy and the least ringing and overshoot. It has the unique ability to be realized in both the frequency and time domains and does not ring in either one. The frequency response of the R&S@RTO 2-GHz oscilloscope along with a maximally-flat response of a 4-GHz oscilloscope (Figure 10) shows that the response of the R&S@RTO is nearly a “textbook” Gaussian shape. In Figure 11, the step response

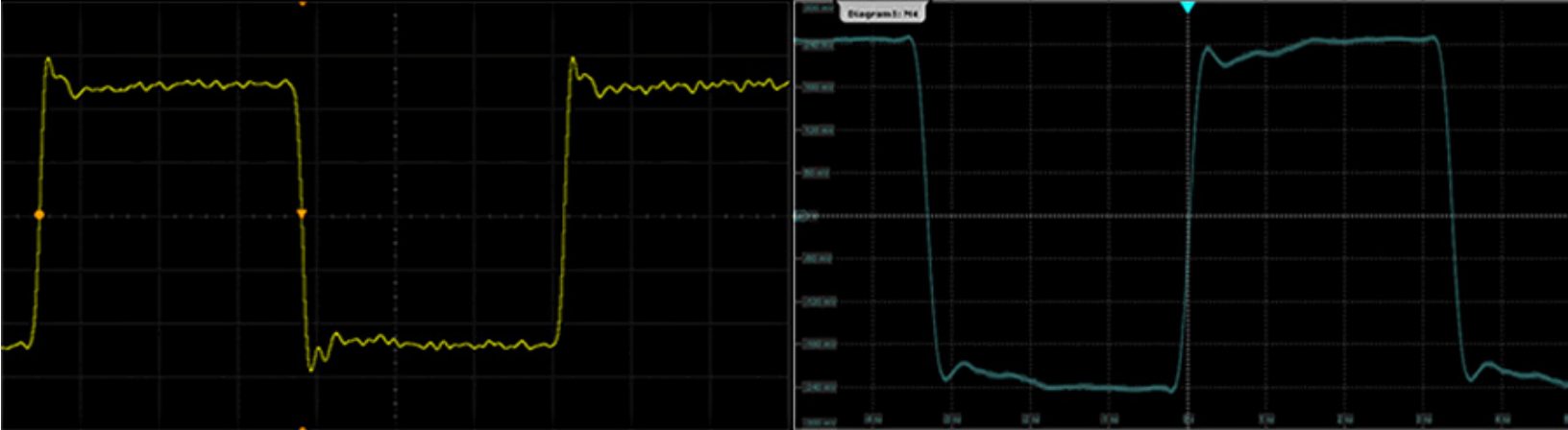

Figure 11: The step responses of the two oscilloscopes show that the R&S®RTO1024 has about 1% overshoot while its maximally flat counterpart exhibits 8% overshoot.

of both oscilloscopes is compared, showing the overshoot of the R&S®RTO to be 1% while the maximally-flat oscilloscope exhibits 8% overshoot. Adopting the Gaussian response requires a trade-off of narrower 3-dB bandwidth because the response rolls off gradually. However, it achieves the highest accuracy (especially at signal edges), eliminates ringing, and has overshoot of less than 1%, far lower than the industry average of 5 to 10% or more. The reduction in overshoot (the maximum amplitude excursion expressed as a percent of the final amplitude) is extremely important as the characteristics of the device under test would otherwise be obscured, making accurate amplitude measurements impossible.

## Gain (Vertical) and Time Base (Horizontal) Accuracy

The oscilloscope's gain accuracy is the determinant of the precision with which its vertical system can vary the amplitude of the input signal, and horizontal accuracy defines the ability of its horizontal system to visualize signal timing.

## ADC Vertical Resolution

Vertical resolution is a metric of the accuracy with which the ADC converts analog voltage to digital bits. For example, an 8-bit ADC converts a signal to 256 discrete voltage levels that are distributed across the selected "volts per division" setting. With 1 mV/division, the least significant bit is 39  $\mu$ V. This is different from effective number of bits as it does not account for non-ideal characteristics within the ADC and the front end of the oscilloscope.

## Vertical Sensitivity

The capability of the vertical amplifier to amplify the strength of the signal is called vertical sensitivity and is

typically about 1 mV per vertical screen division. All oscilloscopes do not have sensitivity as great as 1 mV per division and many rely on software to compensate, which reduces the oscilloscope's effective number of bits. Bandwidth limiting is also sometimes used to address this shortcoming, especially at settings of lower voltage per division.

## Display and User Interface

While individual specifications define an oscilloscope's performance, the display and the interface to the user define how easy the oscilloscope is to use and how well its results are rendered. There is a great deal of consistency among oscilloscope manufacturers concerning the display itself, which today is typically a high-resolution TFT LCD sometimes with LED backlighting. However, the interface itself varies completely with the oscilloscope manufacturer, and is consistently being redefined with each new oscilloscope generation. The ease with which a user can perform measurements as well as the speed and accuracy at which they can be interpreted is subjective so it's wise to evaluate each candidate instrument as thoroughly as possible.

## Communication Capabilities

Digital oscilloscopes today have a wide array of communication interfaces from the traditional GPIB and RS-232 to Ethernet and USB. While the CD-RW drive was previously the way data was moved from place to place, today a simple USB flash drive can do the job easier, and Internet connectivity takes care of more remote transfers. It also allows firmware updates, options, and other features to be downloaded. Ethernet also allows control of the instrument as well as data transfer to be performed anywhere there is an Internet connection, and it allows the oscilloscope to become part of a larger ATE system as well.

# Typical Oscilloscope Measurements

Whether analog or digital, the oscilloscope is a versatile piece of test equipment. Even though its basic function is to measure and display voltage, its capabilities are vastly greater. In addition to the measurements described below, there are many others that apply to specific applications, and application notes and other documents describing them are available widely on the Web. They range from automation of the measurements described here, as well as signal detection and analysis in commercial and defense systems, and a wide array of others.

## Voltage Measurements

The basic voltage measurement is actually only the fundamental step after which many other calculations can be performed. For example, measurement of peak-to-peak voltage is used to calculate the voltage difference between the low and high points of the waveform and measurements can also be made of RMS voltage, which can then be used to determine power level.

## Phase Shift Measurements

An oscilloscope provides a convenient way to measure phase shift with a function called “XY mode”. It is performed by using one input signal in the vertical system and another one in the horizontal system. What results is Lissajous pattern showing relative phases and frequencies of alternating voltages, its shape allowing phase difference and frequency ratio between the two signals to be determined.

## Time Measurements

An oscilloscope can be used to make measurements of time via the horizontal scale, which is useful for evaluating the characteristics of pulses. That is, frequency is the reciprocal of period, so once the period is known, frequency is then 1 divided by the period. The clarity with which the information can be displayed can be improved by making the desired portion of the signal larger.

## Pulse Width and Rise Time Measurements

Evaluation of the width and rise time of pulses is important in many applications as their critical characteristics can become corrupted, which in a digital circuit will cause either degradation or complete failure. Pulse width is defined as the time required for the waveform to rise from 50% of

its peak-to-peak voltage to its maximum voltage and then back. Measurement of negative pulse width determines the time required for the waveform to decline from 50% of its peak-to-peak value to a minimum point. The other parameters related to pulsed signals is their rise time, which is defined as the time required for the pulse to go from 10% to 90% of its full voltage. This industry standard ensures that variations in the pulse’s transition corners are eliminated.

## Decoding of Serial Buses

Decoding of Serial protocols, such as I2C, SPI, UART / RS-232, CAN, LIN, FlexRay and others, is another common set of measurements often performed with an oscilloscope. These measurement capabilities are typically part of one or more oscilloscope software options that can be added as required.

## Frequency Analysis, Statistics and Math Functions

In addition to statistic functions such as histogram and mean and average values, the user can apply math functions to the measured signals. This makes waveform analysis simpler by allowing the user to display the results in a meaningful way. By combining and transforming source waveforms and other data into math waveforms, users can derive the data view that an application requires.

Most oscilloscopes have math functions that allow signals in the different channels to be added, subtracted, multiplied, or divided. Other basic math functions include the Fourier transform that allows the frequency composition of the signal to be viewed on the display, and determination of absolute value shows the voltage value of the waveform.

Mathematical operations, mask tests, histograms, spectrum display, and automatic measurements consume computing resources if implemented in software, increase blind time and cause the instrument to respond slowly. Rohde & Schwarz employed its hardware expertise in spectrum analysis by implementing these functions in hardware, and combined with low-noise frontends and the A/D converter's high number effective bits this provide powerful FFT-based spectrum analysis.

The FFT function is fast, and a high acquisition rate conveys a live spectrum. As a result, rapid signal changes,

interference, and weak superimposed signals are clearly visible.

In the R&S®RTO Series instruments the mask testing functions were also implemented in hardware to preserve high acquisition rates, while achieving large enough number of waveforms required for statistically relevant data. As stored waveforms are available for analysis, signal faults can be detected and their and their causes identified quickly with a high level of confidence.

## Summary

An oscilloscope is a very versatile instrument used in a broad array of engineering environments. Generally speaking, the more effectively implemented the horizontal and vertical systems, the greater the signal fidelity. In addition, trigger flexibility allows the user to set up the oscilloscope with a way to capture signals that appear randomly and infrequently. A good probe or set of probes is essential to get the signal under test into the measurement system. As stated earlier, there are many applications for digital oscilloscopes, and their manufacturers invariably provide ap-

plication notes and other valuable documents that describe them. In addition, there is much more information that in some cases may be useful for each topic described in this document. As a result, once the oscilloscope is purchased, one of the next steps should be to acquire as much information as possible about the specific applications the user is likely to encounter.

# Glossary

## A

**Acquisition mode:** The way waveform points are created from sample points. Standard modes include sample, peak-detect, high-resolution, average, and envelope.

**Analog-to-digital converter (ADC):** The device and the oscilloscope that converts analog input signals to digital bits, the effectiveness of which determines what performance the oscilloscope can achieve.

**Analog signal:** A continuous electrical signal that varies in amplitude or frequency in response to changes in voltage.

**Averaging:** A technique performed by digital signal processing in an oscilloscope that can reduce the noise in the signal and on the display.

## B

**Bandwidth:** The frequency range of the oscilloscope constrained by the point at which its response is reduced by 3 dB (thus 3-dB bandwidth).

## C

**Circuit loading:** The consequence of the probe interacting with the device or circuit under test, the degree of which determines the probe's transparency to both the instrument and the circuit.

## D

**Digital signal:** A signal whose information is a string of bits in contrast with an analog signal that is a continuous range of voltages.

**Digital oscilloscope:** An oscilloscope that converts an analog input signal to a digital representation of it by using an ADC.

**Digital sampling oscilloscope:** An oscilloscope that can analyze signals whose frequencies are higher than the instrument's sampling rate.

**Division:** A vertical and horizontal lines on the oscilloscope's display.

## E

**Effective number of bits (ENOB):** The actual number of bits in an ADC or digital oscilloscope and a determinant of resolution after converting an analog signal to the digital domain. In ADC, it is typically lower than the device's stated number of bits.

**Envelope:** A signal's highest and lowest points after having been captured over a large number of waveform repetitions.

## F

**Frequency response:** A plot that shows how accurately the oscilloscope represents the amplitude of the input

signal over a specific frequency range. The ideal response is ruler flat but remains an ideal and not a practical accomplishment.

## G

**Gain accuracy:** The ability of the vertical system in the oscilloscope to attenuate or amplify the signal.

**Glitch:** A short, typically transient erroneous event that corrects itself, making the process of eliminating its source extremely difficult.

**Graticule:** The vertical and horizontal lines on the oscilloscope display.

## H

**Horizontal sweep:** The process performed by the instruments horizontal system that creates the displayable waveform.

## M

**Mixed-signal oscilloscope:** A digital oscilloscope that has two or four analog channels, 16 digital channels, and functions typically associated with a logic analyzer.

## P

**Peak detection:** A digital oscilloscope of acquisition mode that makes it possible display signals that are critical and difficult to detect.



**Pre-triggering:** A digital oscilloscope's ability to acquire the characteristics of the signal before and after a trigger is enabled.

**Probe:** The input device to the oscilloscope that connects to the device or circuit under test.

## R

**Real-time sampling:** An oscilloscope sampling mode that allows a very large number of samples to be captured from the action of a single trigger.

**Rise time:** The time, between 10% and 90%, required for the leading edge of a pulse to increase from its lowest to highest value.

## S

**Sampling:** The process of acquiring discrete samples of an input signal that are later converted to digital form, and then stored and processed by the oscilloscope.

**Sample point:** The data acquired by an ADC that is used to calculate waveform points.

**Sample rate:** The frequency with which a digital oscilloscope samples the signal, measured in samples per second.

**Single shot:** A transient event acquired by the oscilloscope that occurs only once in the signal stream.

**Slope:** The ratio of vertical to horizontal distance on the display and is positive when it increases from the left to right parts of the display and negative when it decreases.

## T

**Time base:** Instrument circuitry that controls sweep timing.

**Transient:** Also known as a single-shot event, a transient is a signal that occurs only once during the signal capture.

**Trigger:** The oscilloscope subsystem that determines when to display the first instance of a signal.

**Trigger hold-off:** The user-defined minimum interval between triggers used when it is desirable to trigger on the start of a signal rather than an arbitrary part of the waveform.

**Trigger level:** The voltage level that the input signal must attain before a trigger is initiated.

## V

**Vertical resolution:** The precision with which an ADC and an oscilloscope can convert an analog input signal to the digital domain.

**Vertical sensitivity:** The amount by which the vertical amplifier can amplify a signal.

## W

**Waveform point:** The voltage of the signal at a point in time calculated by sample points.

## **About Rohde & Schwarz**

Rohde & Schwarz is an independent group of companies specializing in electronics. It is a leading supplier of solutions in the fields of test and measurement, broadcasting, radiomonitoring and radiolocation, as well as secure communications.

Established more than 75 years ago, Rohde & Schwarz has a global presence and a dedicated service network in over 70 countries. Company headquarters are in Munich, Germany.

## **Customer Support**

I North America | 1 888 837 8772

[customer.support@rsa.rohde-schwarz.com](mailto:customer.support@rsa.rohde-schwarz.com)

I Europe, Africa, Middle East | +49 89 4129 123 45

[customersupport.asia@rohde-schwarz.com](mailto:customersupport.asia@rohde-schwarz.com)

I Latin America | +1 410 910 7988

[customersupport.la@rohde-schwarz.com](mailto:customersupport.la@rohde-schwarz.com)

I Asia/Pacific | +65 65 13 04 88

[customersupport.asia@rohde-schwarz.com](mailto:customersupport.asia@rohde-schwarz.com)

[www.rohde-schwarz.us](http://www.rohde-schwarz.us)

[www.rohde-schwarz-scopes.com](http://www.rohde-schwarz-scopes.com)